

Feb. 15, 1938.

H. COANDA

2,108,652

PROPELLING DEVICE

Filed Jan. 10, 1936

2 Sheets-Sheet 1

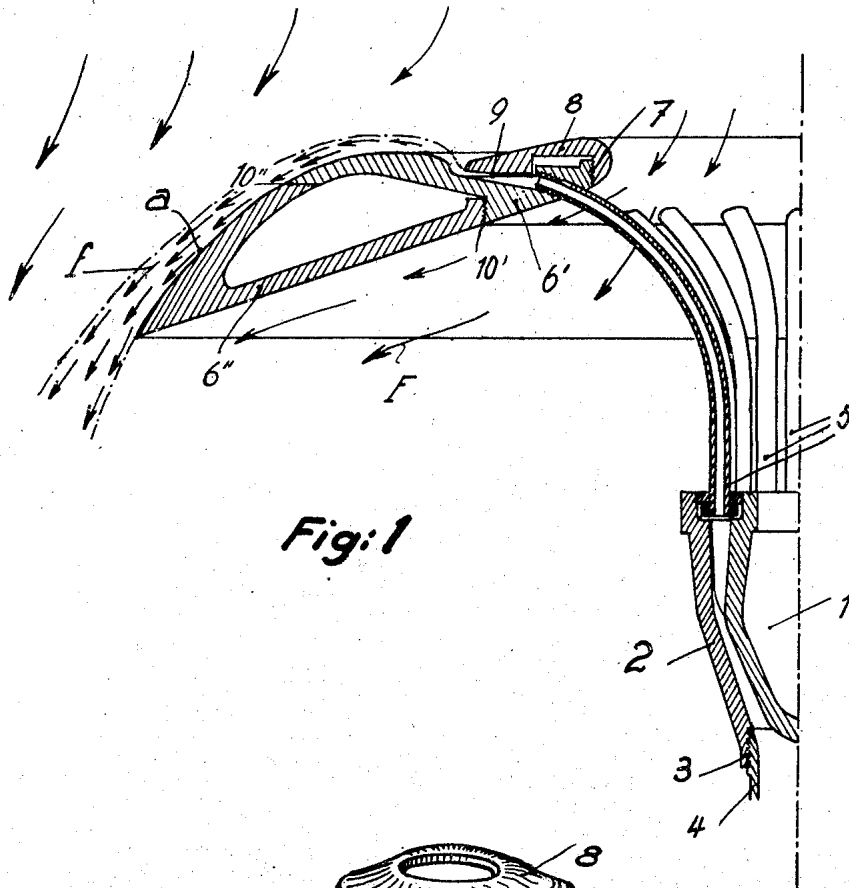

Fig:1

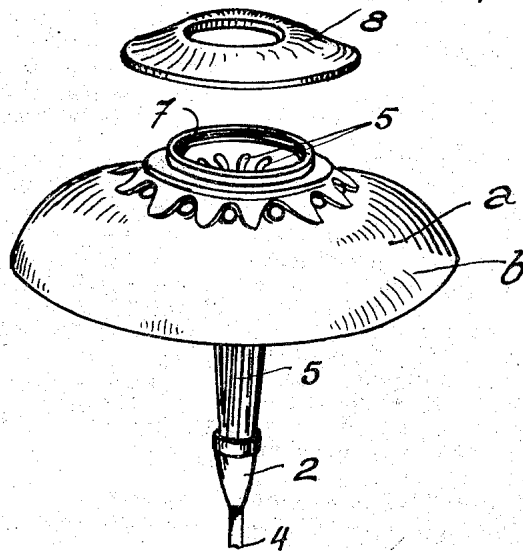

Fig:2

INVENTOR:
HENRI COANDA
BY *Haseltine, Lake & Co*
ATTORNEYS

Feb. 15, 1938.

H. COANDA

2,108,652

PROPELLING DEVICE

Filed Jan. 10, 1936

2 Sheets-Sheet 2

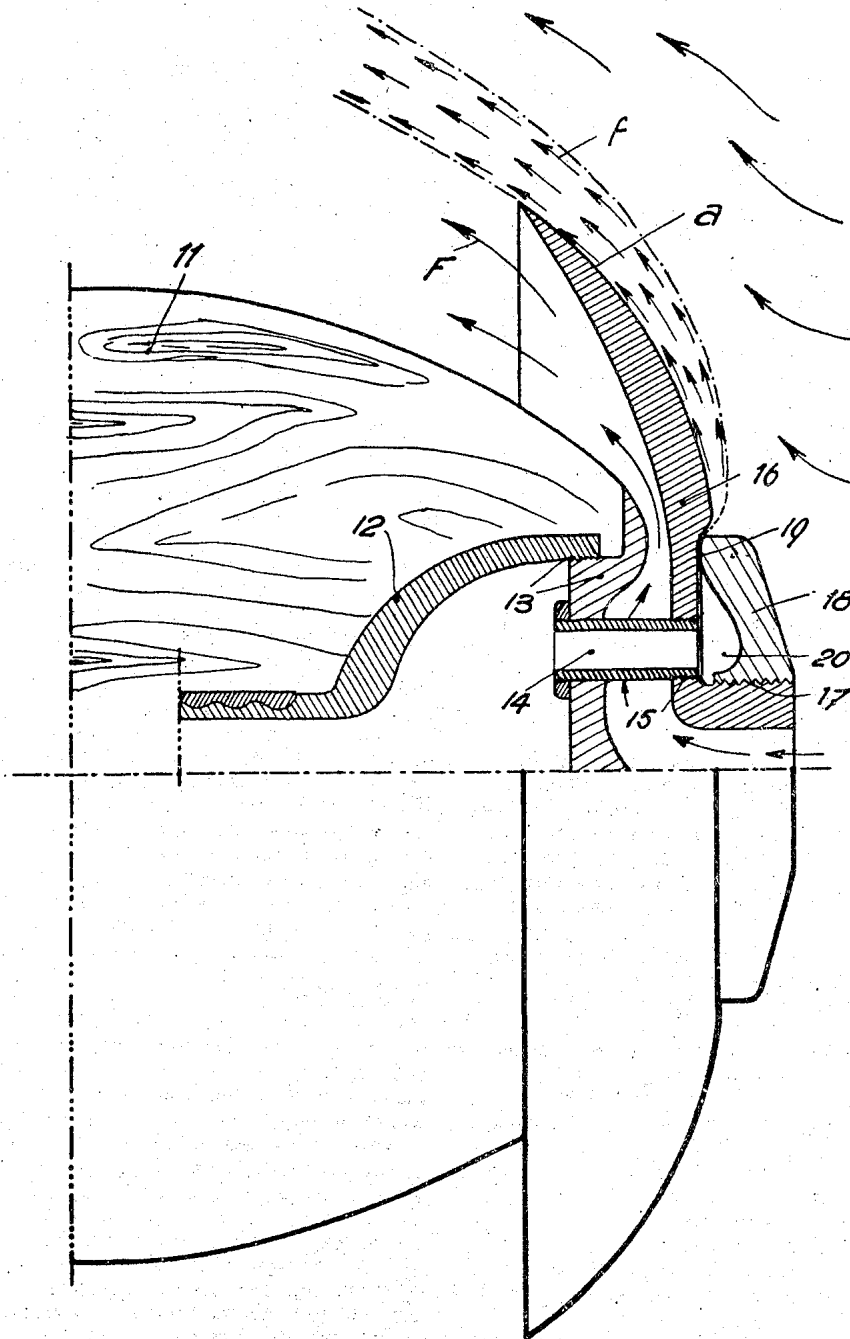

Fig:3

INVENTOR:
HENRI COANDA

BY *Haseltine, Lake & Co.*
ATTORNEYS

UNITED STATES PATENT OFFICE

2,108,652

PROPELLING DEVICE

Henri Coanda, Clichy, France, assignor to Société Anonyme d'Etudes des Brevets et Procédés Coanda-Société Coanda, a corporation of France

Application January 10, 1936, Serial No. 58,471
In France January 15, 1935

10 Claims. (Cl. 244-73)

The present invention relates to propelling devices in which there is produced a suction zone in front of the body in motion on which the propeller is mounted, this suction being such that the body in motion is propelled under the influence of the atmospheric pressure existing at the rear of the propeller.

The object of the present invention is to provide a propelling device of this kind which is better adapted to meet the requirements of practice than those made up to the present time. According to the invention the propeller is composed of an annular structure of suitable axial section, on which a ring fits in an adjustable manner, said ring being concentric and constructed in such a manner that a very narrow gap is formed between it and said annular structure, through which gap compressed gas escapes outwardly along a frontwardly directed line, the axial section of said annular structure consisting of a curve tangent to this line and having its convexity toward the front, while the axial section of said ring is a line making a substantial angle with said first mentioned line.

Furthermore the ring and annular structure are hollow, at least to a certain depth so as to allow air from the space ahead of the propeller to flow through their central portion and out behind the annular structure. This prevents any suction at the rear of the annular structure so that the whole of the suction is in front thereof, and the motion of the body is ensured by the difference between the pressure at the front and that at the rear.

Preferred embodiments of the present invention will be hereinafter described with reference to the accompanying drawings, given merely by way of example and in which

Figs. 1 and 2, show in perspective and sectional views respectively a first embodiment of the invention,

Fig. 3 is a sectional view of a modification,

In the embodiment of Figs. 1 and 2, the body of the propelling device according to the invention includes an inner element 1 and a tubular part 2, fitted thereon and provided at 3 with screw threads for fixation of a tube 4. This structure carries a series of tubes 5 opening into an annular member 6. Another annular member 8 is screwed at 7 on member 6, so that the narrow annular interval 9 between members 6 and 8 can be adjusted at will.

Member 6 may be made of a single piece or consist of two rings 6', 6'' screwed to each other at 10', 10''.

In the embodiment of Fig. 3, the streamline body 11 contains a part screwed to the member 13. Tubes 14 are provided in member 13 and secured by the screw thread 15 in a ring 16 of suitable profile upon which a ring 18 is fixed by screw threads 17, so that this ring 18 can be adjusted in position with respect to ring 16.

Between ring 16 and ring 18 there is left an adjustable narrow annular interval 19, ring 18 being however constructed so as to form a circular chamber 20 between said ring and ring 18.

The propeller works in the following manner:

The compressed gas, which may consist of superheated steam or a combustible mixture or some explosive mixture or even compressed air, is supplied through tube 4, flows through the annular space formed between elements 1 and 2, passes through tubes 5 into the narrow annular interval 9 between the element 6 and ring 8 and escapes into the atmosphere.

The fluid film expands and exceeds its initial volume, and, owing to the fact that on one side of the outlet of passage 9, annular member 6 is substantially tangent to the fluid sheet escaping from 9, whereas, on the other side, the edge of member 8 makes a substantial angle to the direction of said sheet, the latter flows along the front face of member 6, following the path indicated by arrows *f*. Thus in the space marked in dotted lines a rush of fluid is created toward which the surrounding air is drawn in the direction of the arrows *f* provided the pressure of the motive fluid is sufficient.

Therefore the propeller, owing to the suction created at its front part, has a tendency to rush forward under the action of the pressure existing behind it, drawing along the structure on which it is mounted provided the outflow is sufficient to create a momentum at low speed and in great masses of the surrounding air, equivalent to the drag of the body in which the propeller is mounted.

Moreover the surrounding air circulates through the central free portion in the direction of the arrows *F*, at same pressure, so that below the part 6 a counterpressure is created relative to the suction in front of the same, which counter pressure consequently adds to the action of the suction created in front of part *a*.

The same applies in the case of Fig. 3. The gaseous mixture under high pressure which is to expand after entering the chamber formed by part 12, passes through tube 14, starts expanding in chamber 20 and escapes through annular interval 19 following the front face of element 16,

creating in front of it a zone of very strong suction represented by dotted lines.

It is evident that the shape of elements such as 6' and 16 and the thickness of annular intervals 9 or 19 are calculated in such a manner that a certain expansion of the compressed motive fluid permits of obtaining a momentum which ensures the displacement of the body.

In a general manner, while I have, in the above description, disclosed what I deem to be practical and efficient embodiments of the present invention, it should be well understood that I do not wish to be limited thereto as there might be changes made in the arrangement, disposition and form of the parts without departing from the principle of the present invention as comprehended within the scope of the appended claims.

It may be noted that in Fig. 1 the member 8 and in Fig. 3 the part 18 extend at least with the edge into a recess at the front of the moving body, with the result that the air or fluid issuing from the narrow slot first strikes the curved portion of the airfoil or wing shaped member so as to follow its curvature forwardly and then outward radially and subsequently rearwardly.

Having now fully described my invention, I claim:

1. A propelling device of the type described, which comprises, in combination, a body, an annular member rigid with said body at the front part thereof, another annular member rigid with said body, coaxial with the first annular member and located ahead thereof, so as to leave between said members a narrow annular interval with a flaring outlet opening to the atmosphere in a frontward direction, the rear edge or lip of said outlet, formed by the front surface of the first mentioned annular member, being of rounded shape starting tangentially to said frontward direction on the outer side thereof, with its convexity toward the front, whereas the front edge or lip of said outlet, formed by the front surface of the second mentioned annular member, starts at an angle to said direction on the inner side thereof, and means for driving out a fluid under high pressure through said annular outlet.

2. A propelling device of the type described, which comprises, in combination, a body, an annular member rigidly fixed to said body at the front part thereof, another annular member rigidly fixed to said body in coaxial relation with the first annular member and ahead thereof, said members being so positioned and shaped as to form between them a narrow annular interval with a flaring outlet opening to the atmosphere in a frontward direction, the rear edge or lip of said outlet, formed by the front surface of the first mentioned annular member, being of rounded shape starting tangentially to said frontward direction on the outer side thereof, with its convexity toward the front, whereas the front edge or lip of said outlet, formed by the front surface of the second mentioned annular member, starts at an angle to said direction on the inner side thereof, and means for driving out a fluid under high pressure through said annular outlet.

3. A propelling device of the type described, which comprises, in combination, a body, an annular member rigidly fixed to said body at the front part thereof, with a space between the rear face of said member and said body, whereby air from the front of said member can flow

through the inner aperture thereof and through said space to the lateral sides of said body, another annular member rigidly fixed to said body in coaxial relation with the first mentioned annular member and ahead thereof, said members being so positioned and shaped as to form between them an annular interval with a flaring outlet opening to the atmosphere in a frontward direction, the rear edge or lip of said outlet, formed by the front surface of the first mentioned annular member, being of rounded shape starting tangentially to said frontward direction on the outer side thereof, with its convexity toward the front, whereas the front edge or lip of said outlet, formed by the front surface of the second mentioned annular member, starts at an angle to said direction on the inner side thereof, and means for driving out a fluid under high pressure through said annular outlet.

4. A propelling device of the type described, which comprises, in combination, a body, an annular member rigidly fixed to said body at the front part thereof, with a space between the rear face of said member and said body, whereby air from the front of said member can flow through the inner aperture thereof and through said space to the lateral sides of said body, another annular member rigidly fixed to said body, in coaxial relation with the first mentioned annular member, and ahead thereof, said members being so positioned and shaped as to form between them an annular chamber having an annular flaring outlet opening to the atmosphere in a frontward direction, the rear edge or lip of said outlet, formed by the front surface of the first mentioned annular member, being of rounded shape starting tangentially to said frontward direction on the outer side thereof, with its convexity toward the front, whereas the front edge or lip of said outlet, formed by the front surface of the second mentioned annular member, starts at an angle to said direction on the inner side thereof, and means for feeding a fluid under high pressure to said annular chamber between said members, the last mentioned means including a plurality of tubes extending from said body and opening into said chamber.

5. A propelling device of the type described which comprises, in combination, a body of hollow shape forming a container for a fluid under high pressure, an annular member rigidly fixed to said body at the front part thereof, with a space between said body and the rear face of said member, whereby air can flow from the front of said annular member, through the central aperture thereof and through said space, to the lateral sides of said body, another annular member rigidly fixed to said first mentioned annular member coaxially therewith and ahead thereof, said members being so positioned and shaped as to form between them an annular chamber having an annular flaring outlet opening to the atmosphere in a frontward direction, the rear edge or lip of said outlet, formed by the front surface of the first mentioned annular member, being of rounded shape starting tangentially to said frontward direction on the outer side thereof, with its convexity toward the front, whereas the front edge or lip of said outlet, formed by the front surface of the second mentioned annular member, starts at an angle to said direction on the inner side thereof, and a plurality of pipes connecting the inside of said body with said annular chamber for feeding fluid under high pressure to said chamber.

6. A propelling device of the type described, which comprises, in combination, an elongated body having one end serving as a forward portion or nose, a fixed surface member of wing-shaped section rigidly carried exteriorly upon the forward portion of said body in spaced relation to the latter and with the chord of said section practically transversely disposed with respect to the forward direction upon the body, the front surface of said member being convex in said forward direction and arching rearwardly away from said body from a recess or depressed portion in the foremost part of said forward portion, rigid spaced means upon said fixed member spaced a small distance from the latter member in said recess or depressed portion so as to determine at least one narrow slot communicating with the interior of said body and allowing a sheet of fluid to be projected at high pressure from within the body out through said slot and against the convex front surface of said fixed member in said recess and caused to follow said curved surface first forwardly out of the recess and then outwardly and rearwardly along the arching portion of said curved surface upon said fixed member, and open means upon the forward portion of said propelling device allowing free access of air to the rear surface of said fixed surface member between the same and the body independently of the fluid supply escaping from the interior of said body through said narrow slot.

7. A propelling device according to claim 6, wherein the fixed surface member is annular so as to surround the nose of the device, and the slot means extends around said nose in the recess which is also extended about the device to be annular in form.

8. A propelling device of the type described, which comprises, in combination, an annular elongated body having one end serving as a forward portion or nose, a fixed annular surface member of wing-shaped section rigidly carried exteriorly upon the forward portion of said body in spaced relation to the latter and surrounding the same with the chord of said section practically transversely disposed with respect to the forward direction upon the body, the front surface of said annular member being convex in said forward direction and arching rearwardly away from said body, rigid spaced means upon said fixed member spaced a small distance from the latter member so as to determine at least one narrow slot communicating with the interior of said body and allowing a sheet of fluid to be projected at high pressure from within the body out through said slot and caused to follow said curved surface outwardly and rearwardly along the arching por-

tion of said curved surface upon said fixed and annular member, there being a free and open passage extending rearwardly from the forward portion of the device and communicating in unbroken manner with the space between said fixed annular member and said body allowing atmospheric air to enter freely and relieve any tendency to form a vacuum upon the rear surface of said annular member, and a plurality of fluid supply tubes connecting the interior of said body with said narrow slot through said space between the annular fixed member and said body and independently thereof.

9. A propelling device according to claim 8, wherein the fluid supply tubes serve as the exclusive mechanical means for supporting the fixed annular member upon and spacing the same away from the main body of the device.

10. A propelling device of the type described, which comprises, in combination, an elongated body having one end serving as a forward portion or nose, a fixed annular surface member of wing-shaped section rigidly carried exteriorly upon the forward portion of said body in spaced relation to the latter and surrounding the same with the chord of said section practically transversely disposed with respect to the forward direction upon the body, the front surface of said annular fixed member being convex in said forward direction and arching rearwardly away from said body from an annular recess or depressed portion in the foremost part of said forward portion, rigid spaced means upon said fixed member spaced a small distance from the latter member in said recess or depressed portion so as to determine at least one narrow slot communicating with the interior of said body and allowing a sheet of fluid to be projected at high pressure from within the body out through said slot and against the convex front surface of said fixed member in said annular recess and caused to follow said curved surface first forwardly out of the recess and then outwardly and rearwardly along the arching portion of said curved surface upon said fixed annular member, there being a free and open passage extending rearwardly from the forward portion of the device and communicating in unbroken manner with the space between said fixed annular member and said body allowing atmospheric air to enter freely and relieve any tendency to form a vacuum upon the rear surface of said annular member, and a plurality of fluid supply tubes connecting the interior of said body with said narrow slot through said space between the annular fixed member and said body and independently thereof.

HENRI COANDA.